

Do not use powered screw drivers for adjustment.

FITTINGS

- 12 of 3.9x13 Self tapping screw pan head
- 8 of 4x16 Self tapping screw countersunk head
- 4 of M4x5 Special machine screw
- 2 of M6x10mm Pan head machine screw
- 2 of M6 Washer

COMPONENTS

- A. Metal frame
- B. Kit Grass slides (pair)
- C. Slide cover
- D. Lid holder (Pair)
- E. Lid
- F. Door fixing brackets
- G. Door bracket cover
- H. Stopper
- I. Wastebin 35L

MAINTENANCE

Clean with a soft, dry cloth. Avoid using solvents or abrasive.
Plastic waste bins can be washed with warm water and mild detergent.
Allow to dry completely before use.

TOOLS

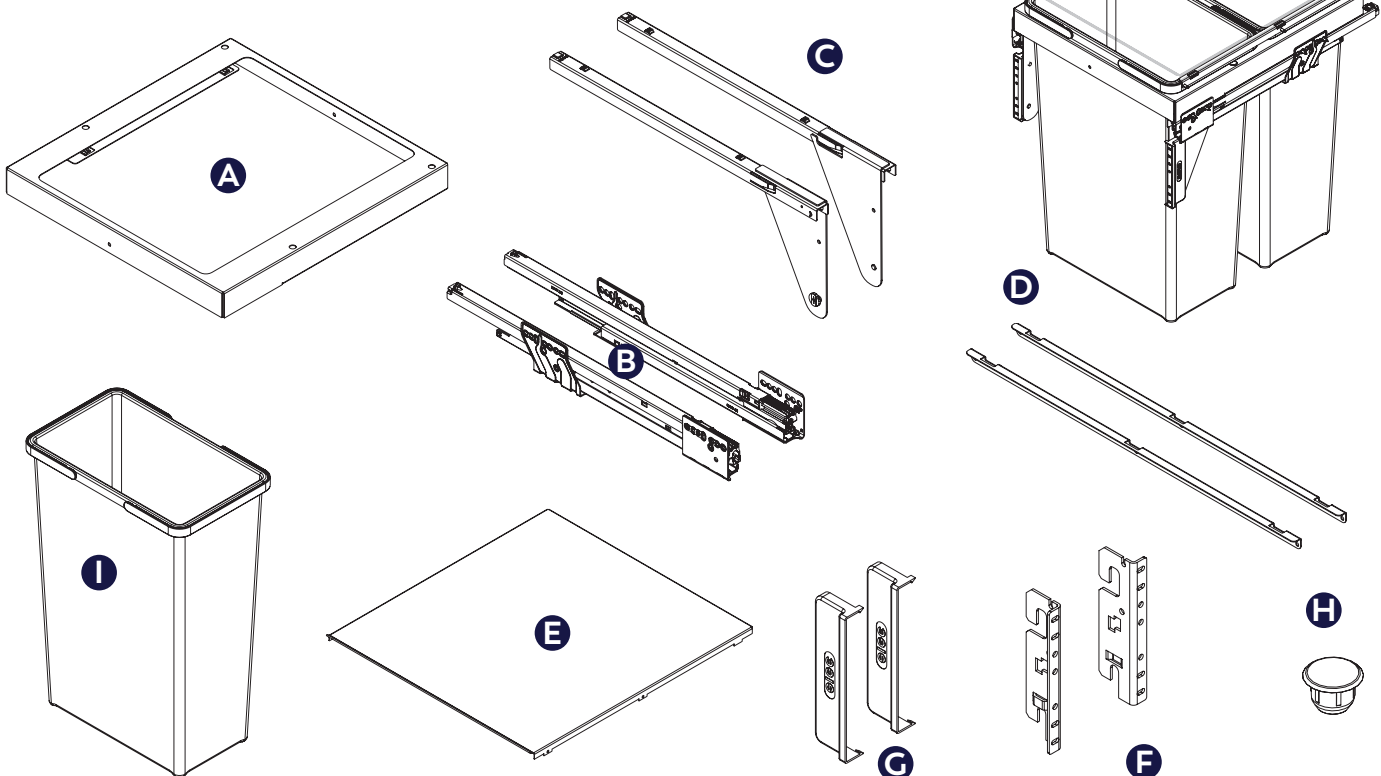
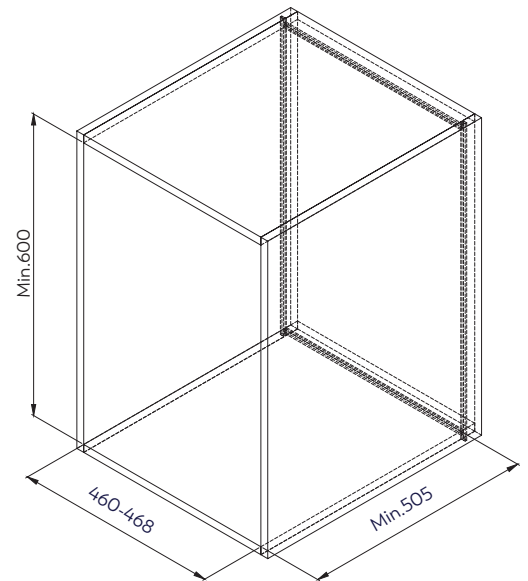



4 of 3.9x13 Self tapping screw pan head
8 of 4x16 Self tapping screw countersunk head



1

Fix the Grass slides (B) and the lid holder (D) according to the dimensions shown.

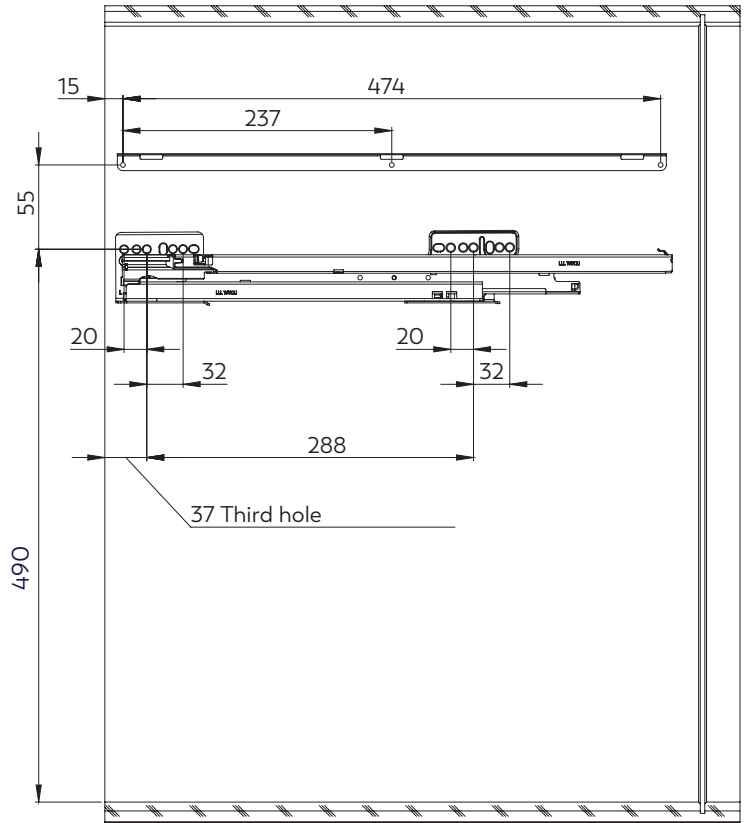
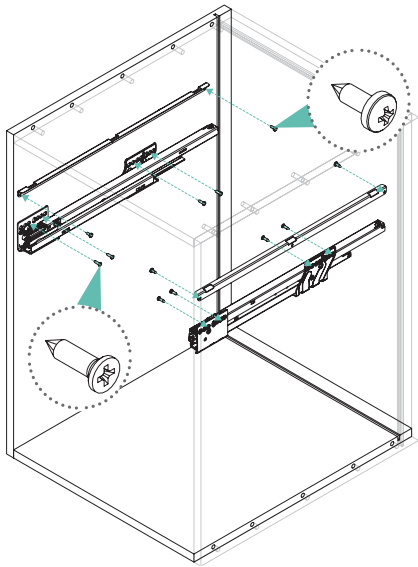

2

Clip the slide Covers (C) into the Grass slides (B).

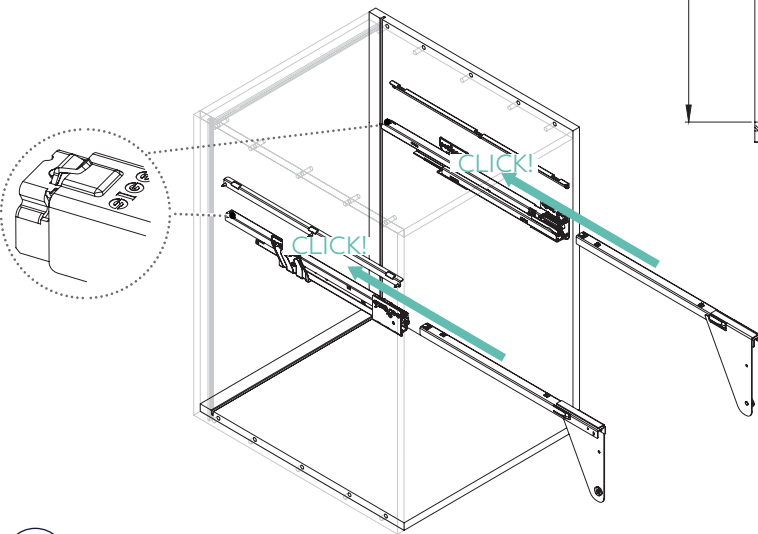

4 of M4x5 Special machine screw



3

Screw the metal frame (A) into the slide cover (C) by using the specific provided screws.

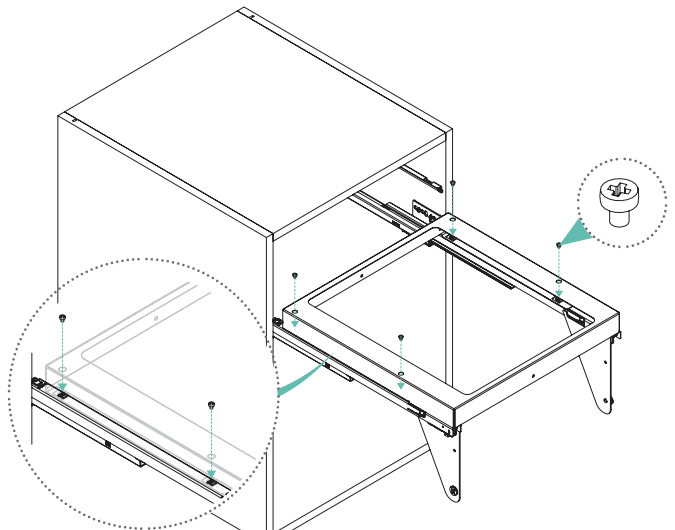
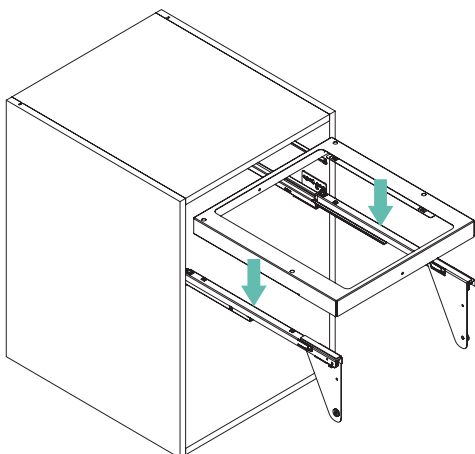



4 of M4x5 Self tapping screw pan head



4

Attach the door fixing brackets (F) according to the dimensions shown.

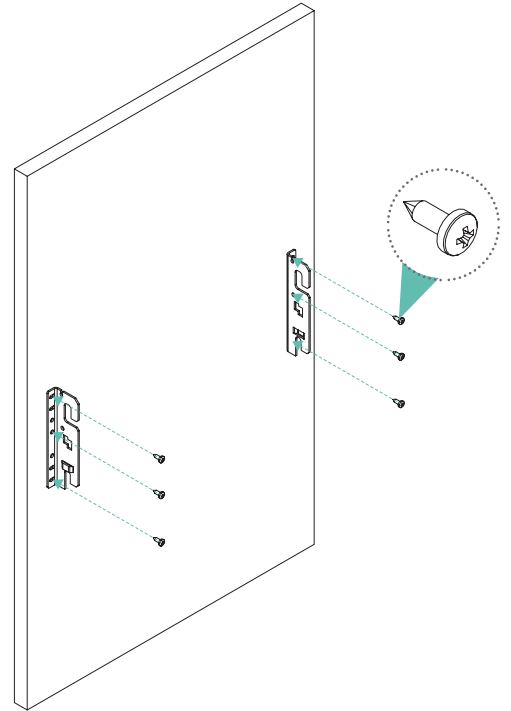
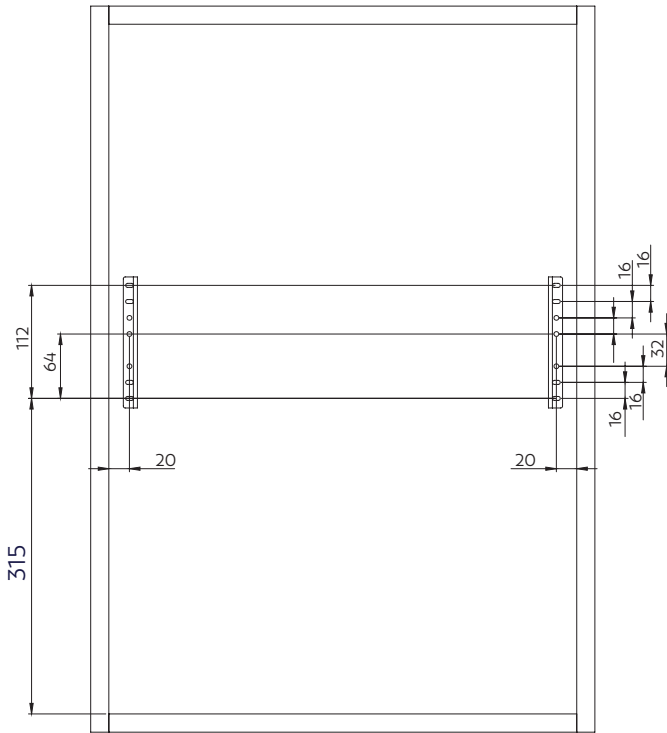

2 of M6x10mm Pan head machine screw
2 of M6 Washers



5

Pre-assemble the M6x10 screws and washers then mount the door on the slide covers (C) as shown.

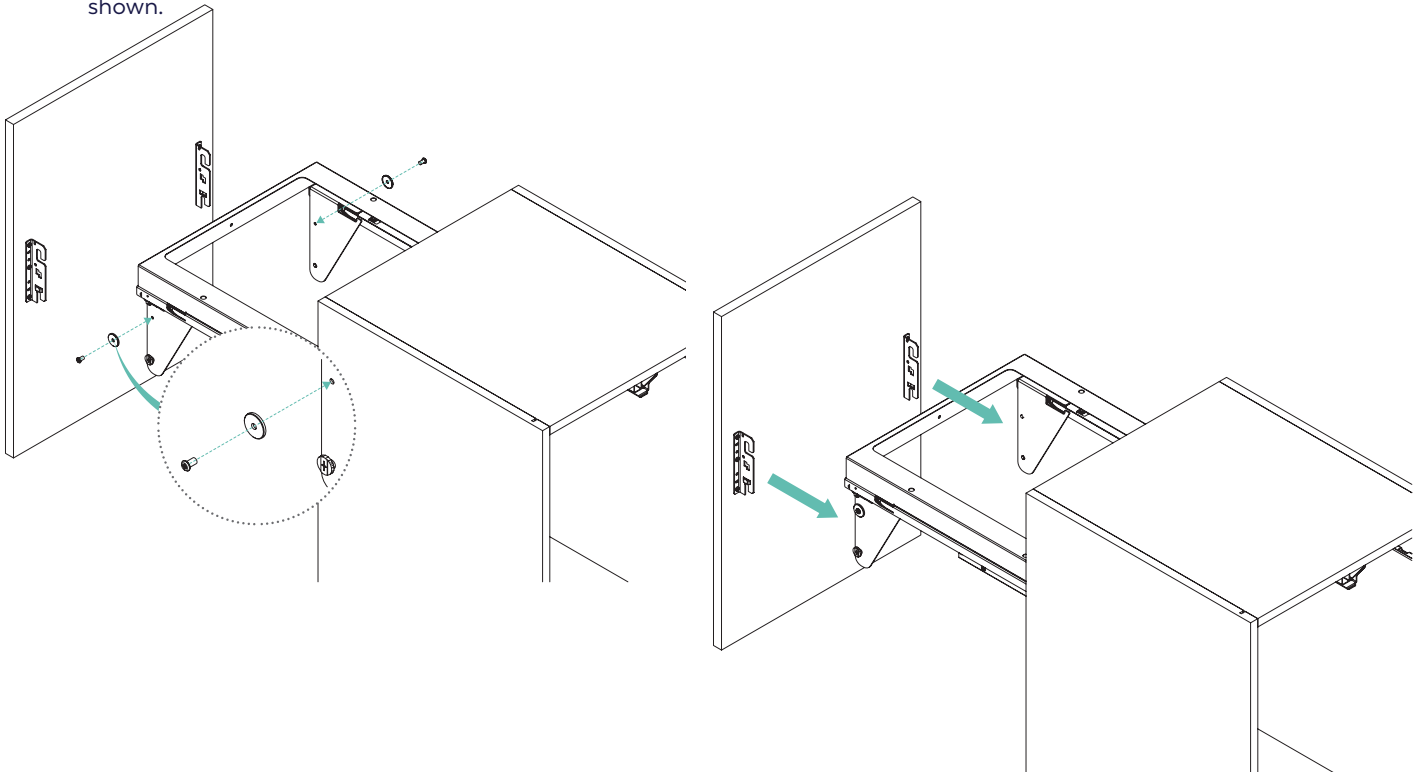

6

Adjust the door up and down by turning the eccentric screw.

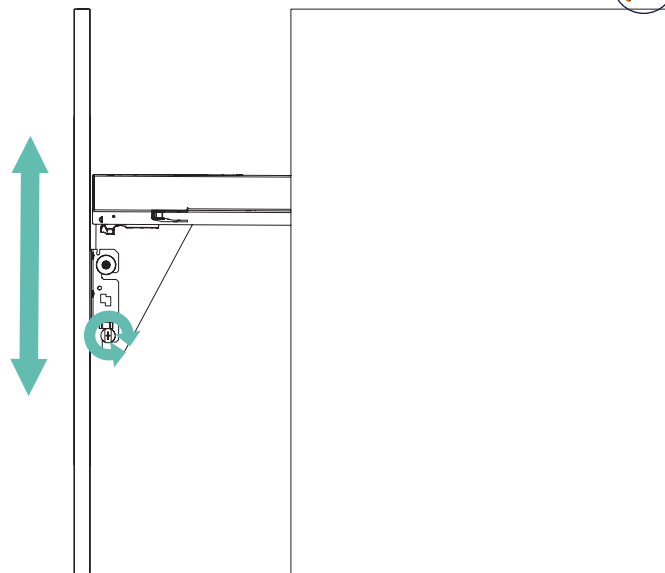

7

Adjust the door inclination to the front or to the back, then tighten the two M6x10 screws.

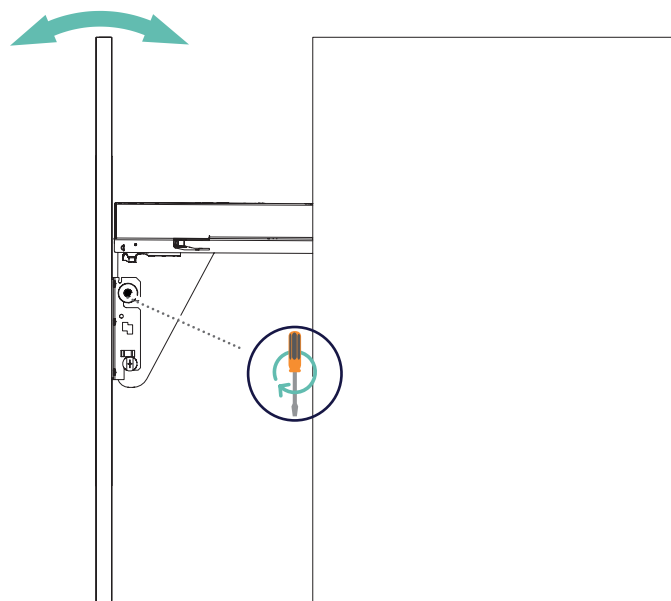

8

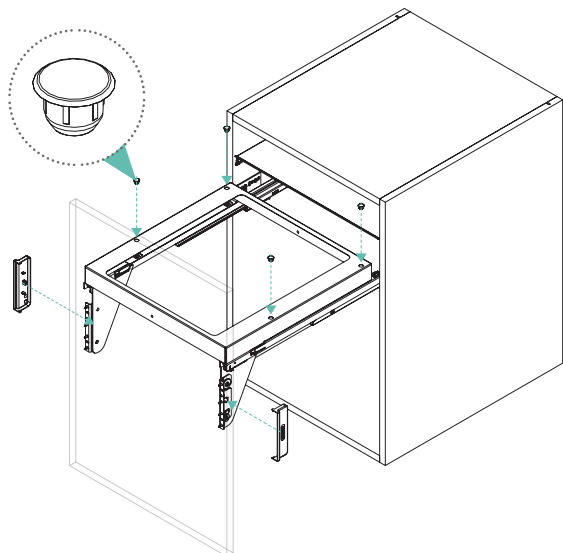
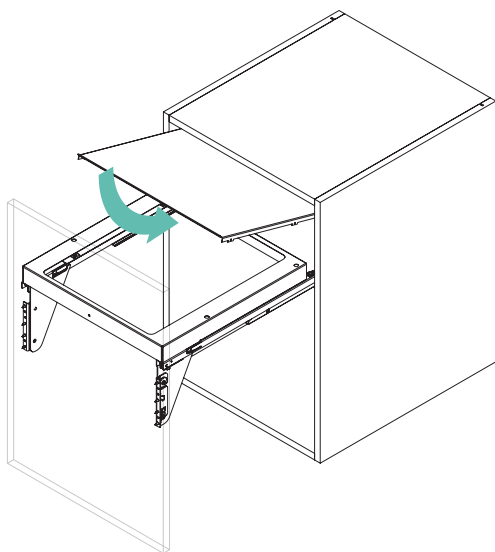

9

